



Features

- . Input 90V to 264VAC, 50~60Hz suitable for worldwide use
- . Output voltage optional from 12V to 48Vdc constant voltage
- . Protections: Short Circuit / Overload / Over Voltage Protection
- . 100% full load burn-in test for 2Hrs to make every unit reliable
- . Small and compact size, built-in active PFC function
- . With power good and fail signal output, high efficiency upto 93%
- . Long life and high reliability design with 3 years warranty

Safety Standards

- . IEC62368-1 CB report for worldwide use
- . UL62368-1 + CAN/CSA 62368-1 for USA and Canada
- . EN 62368-1:2014/A11:2017 for European Union
- . AS/NZS 62368.1:2018 for Australia and New Zealand
- . J62368-1 for Japan and GB4943.1 for China market.



Product Description:

It is a highly reliable and quality 300W open frame switching power supply solution with wide range 90-264Vac input and designed strictly according to the international safety standards. It's built-in PFC function with PF>0.93. The maximum output power is 200W by free air convection and 300W by 20.5CFM fan force air convection. The entire series supplies different models with output voltages ranging between 12Vdc and 48Vdc that can satisfy the demands for various types of consumer electronic devices, household electronic device, communication device and so on. The 300W open frame type switching power supply solution is built-in full protections of over load / short circuit and over voltage with small and compact size of 127.0 x 76.2 x 35mm.

Technical Specification

Typ. Model	KEPP-300-12	KEP-300-15	KEPP-300-24	KEPP-300-27	KEPP-300-48
Output					
Output Voltage	12VDC	15VDC	24VDC	27VDC	48VDC
Rated Current (convection)	16.67A	13.33A	8.33A	7.4A	4.17A
Rated Current (20.5CFM)	25A	20A	12.5A	11.12A	6.25A
Output Power	300W Max.	300W Max.	300W Max.	300W Max.	300W Max.
Voltage Tolerance	±3%	±3%	±2%	±2%	±2%
Ripple & Noise	200mVp-p	200mVp-p	250mVp-p	300mVp-p	350mVp-p
Input					
Input voltage	90 - 264Vac or 120- 370Vdc				
Input Frequency	50-60Hz (When the input is AC)				
Input Current	3.5A Max. @ 100 ~240Vac 50/60Hz input				
Inrush Current	80A Max. @ 100 ~240Vac 50/60Hz input				
Efficiency (Typ.)	90%	90%	92%	93%	93%
Leakage Current	≤2mA @ full input range				
Protections					
Over current	105~135% rated output power. Auto-Recovery when the fault is removed				
Short Circuit	No damage. Auto-Recovery when the fault is removed				
Over temperature	Shut down o/p voltage, re-power on to recover				
Environmental					
Operation Temperature	-20°C to +40°C, 20%RH to 90%RH				
Storage Temp, Humidity	-45~ +85°C, 10%RH to 95%RH				
Operation Altitude	≤5000m @ full load and rated operating temperatures				
MTBF	≥50000Hrs @ full load and rated operating temperatures				
Mechanical					
Dimensions (L x W x H)	127.0 x 76.2 x 35.0mm (5.00 x 3.00 x 1.38 inch)				
Unit Weight	370g±20 grams				
Packing Information	36pcs/ Carton, carton dimensions:47*37*20cm, 14.3kgs/ Carton				

TEST REPORT

OUTPUT FUNCTION TEST

NO	TEST ITEM	SPECIFICATION	TEST CONDIDTION	RESULT	VERDICT
1	RIPPLE & NOISE	200mVp-p (Max)	I/P:230VAC / O/P:FULL LOAD / Ta:25°C	122mVp-p	P
2	VOLTAGE TOLERANCE	-3% ~ +3% (Max)	I/P:90VAC~264VAC O/P:FULL~MIN. LOAD / Ta:25°C	-1.3% ~ +1.3% of output voltage	P
3	LINE REGULATION	-1% ~ +1% (Max)	I/P:90VAC ~264VAC O/P:FULL LOAD / Ta:25°C	-0.06% ~ +0.06% of output voltage	P
4	LOAD REGULATION	-1% ~ +1% (Max)	I/P:230VAC O/P:FULL ~MIN LOAD / Ta:25°C	-0.63% ~ +0.63% of output voltage	P
5	OVER/UNDERSHOOT	<±5%	I/P: 230VAC O/P:FULL LOAD / Ta:25°C	1.1%	P
6	SET UP TIME	3000 mS (Max)	I/P:230VAC O/P:FULL LOAD / Ta:25°C	1850 mS	P
7	RISE TIME	30 mS (Max)	I/P: 230VAC O/P:FULL LOAD / Ta:25°C	26 mS	P
8	HOLD UP TIME	13 mS (Min)	I/P: 115VAC O/P:FULL LOAD / Ta:25°C	18 mS	P

INPUT FUNCTION TEST

NO	TEST ITEM	SPECIFICATION	TEST CONDIDTION	RESULT	VERDICT
1	VOLTAGE RANGE	90VAC~264VAC	I/P:TESTING O/P:FULL LOAD / Ta:25°C	82V~264V	P
2	FREQUENCY RANGE	50HZ - 60HZ (Typ) NO DAMAGE OSC	I/P: 100VAC ~ 240VAC O/P:FULL~MIN LOAD / Ta:25°C	TEST: OK	P
3	EFFICIENCY	90% (Typ)	I/P:230VAC O/P:FULL LOAD / Ta:25°C	90.66%	P
4	AVERAGE EFFICIENCY	>87%	I/P:115/230VAC & O/P:25%、50%、75%、100% LOAD & Ta:25°C	88.33% (115VAC) 88.79% (230VAC)	P
5	AC CURRENT	3.5A (Max)	I/P:100VAC & O/P:FULL LOAD Ta:25°C	3.12A	P
6	INRUSH CURRENT	<80A COLD START	I/P: 230VAC / O/P:FULL LOAD Ta:25°C	66.8A	P
7	LEAKAGE CURRENT	< 2.0mA	I/P:240VAC & O/P:Min LOAD Ta:25°C	L-FG:1.23mA N-FG:1.33mA	P

PROTECTION FUNCTION TEST

NO	TEST ITEM	SPECIFICATION	TEST CONDIDTION	RESULT	VERDICT
1	OVER LOAD PROTECTION	105 ~ 135% (Typ)	I/P:230VAC & O/P:TESTING Ta:25°C	113.6% HICCUP MODE	P
2	OVER VOLTAGE PROTECTION	115 ~ 135% (Typ)	I/P:230VAC O/P:MIN LOAD & Ta:25°C	Hiccup mode ,recovers automatically after fault condition is removed	P
3	SHORT PROTECTION	SHORT OUTPUT 1 HOUR NO DAMAGE	I/P:264VAC O/P:FULL LOAD & Ta:25°C	NO DAMAGE HICCUP MODE	P

SAFETY TEST & E.M.C TEST

NO	TEST ITEM	SPECIFICATION	TEST CONDIDTION	RESULT	VERDICT
1	WITHSTAND VOLTAGE	I/P-O/P: 3KVAC/min I/P- FG: 2KVAC/min O/P-FG:0.5KVAC/min	I/P-O/P: 3.6 KVAC/min I/P-FG: 2.4KVAC/min O/P-FG: 0.6KVAC/min Ta:25°C	I/P-O/P:5.80mA I/P-FG: 5.38mA O/P-FG: 2.16mA NO DAMAGE	P
2	ISOLATION RESISTANCE	I/P-O/P:500VDC>100MΩ I/P-FG: 500VDC>100MΩ O/P-FG:500VDC>100MΩ	I/P-O/P: 500 VDC I/P-FG: 500 VDC O/P-FG: 500 VDC Ta:25°C	I/P-O/P: 9999MΩ I/P-FG: 9999MΩ O/P-FG: 9999MΩ NO DAMAGE	P
3	CONDUCTION	BS EN/EN55032(CISPR32), FCC PART 15 / CISPR22 CAN	I/P: 230 VAC (50HZ) O/P: FULL/50% LOAD Ta: 25°C	PASS Test by certified Lab	P
4	RADIATION	BS EN/EN55032(CISPR32), FCC PART 15 / CISPR22 CAN	I/P: 230 VAC (50HZ) O/P: FULL LOAD Ta: 25°C	PASS Test by certified Lab	P
5	SURGE	BS EN/EN61000-4-5 LIGHT INDUSTRY L-N: 1KV	I/P: 230 VAC/50HZ O/P: FULL LOAD Ta: 25°C	CRITERIA B	P
6	E.S.D	BS EN/EN61000-4-2 LIGHT INDUSTRY AIR: 8KV / Contact: 4KV	I/P: 230 VAC/50HZ O/P: FULL LOAD Ta: 25°C	CRITERIA B	P

TEST RESULT	TESTER	REVIEW	APPROVAL
PASS	ZHU LI	WANG LW	ZHANG DL

Mechanical Specification

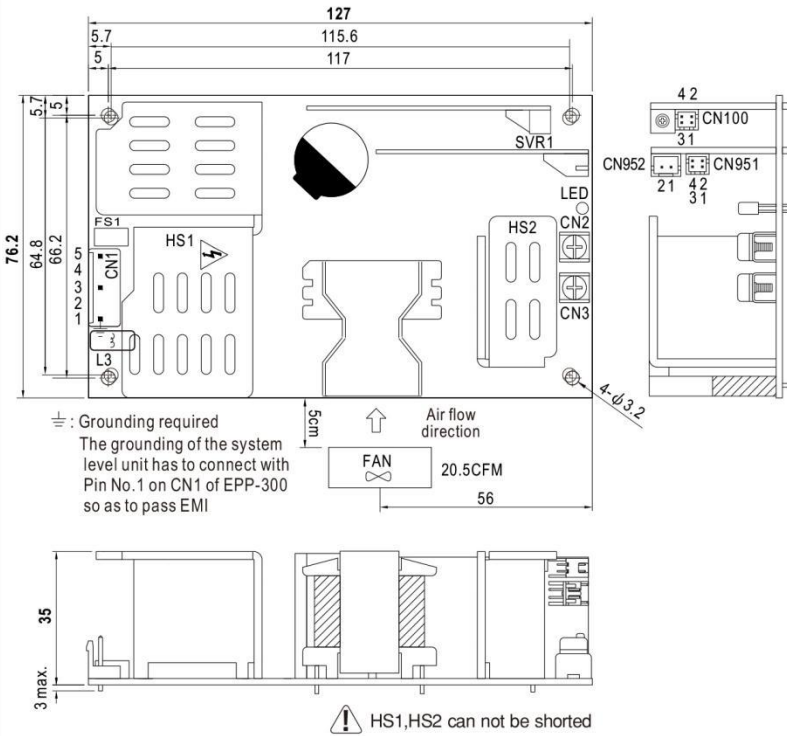

Unit:mm

AC Input Connector (CN1) : JST B5P-VH or equivalent

Pin No.	Assignment	Mating Housing	Terminal
1	FG	JST VHR or equivalent	JST SVH-21T-P1.1 or equivalent
2,4	No Pin		
3	AC/L		
5	AC/N		

DC Output Connector (CN2,CN3)

Pin No.	Assignment	Output Terminals
CN2	-V	M3.5 Pan HD screw in 2 positions
CN3	+V	Torque to 8 lbs-in(90cNm)max.

Function Connector(CN100):HRS DF11-4DP-2DS or equivalent

Pin No.	Status	Mating Housing	Terminal
1	-S	HRS DF11-4DS or equivalent	HRS DF11-**SC or equivalent
2	+S		
3	DC COM		
4	PG		

Function Connector(CN951):HRS DF11-4DP-2DS or equivalent

Pin No.	Status	Mating Housing	Terminal
1	5VSB	HRS DF11-4DS or equivalent	HRS DF11-**SC or equivalent
2,4	DC COM		
3	PS-ON		

FAN Connector(CN952) : JST S2B-XH or equivalent

Pin No.	Assignment	Mating Housing	Terminal
1	DC COM	JST XHP or equivalent	JST SXH-001T-P0.6 or equivalent
2	+12V		

Block Diagram

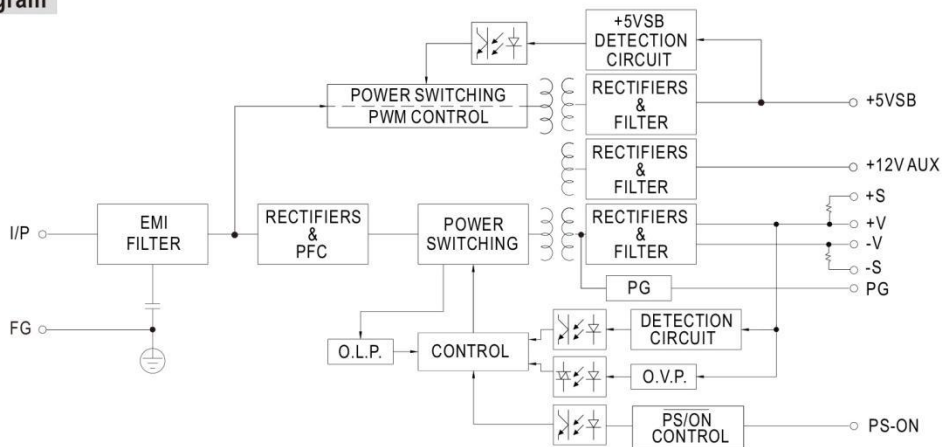

Derating Curve

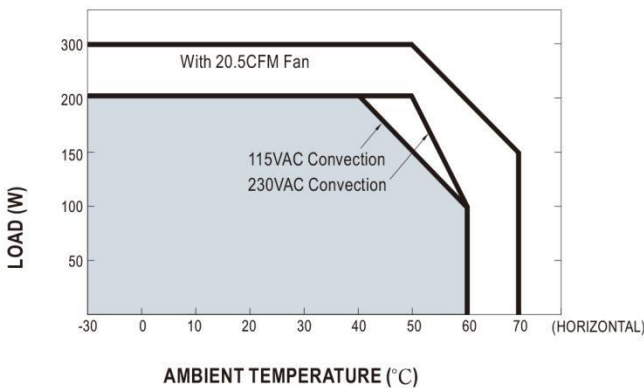

Output Derating VS Input Voltage

